

WFM1020A Assembly Instructions

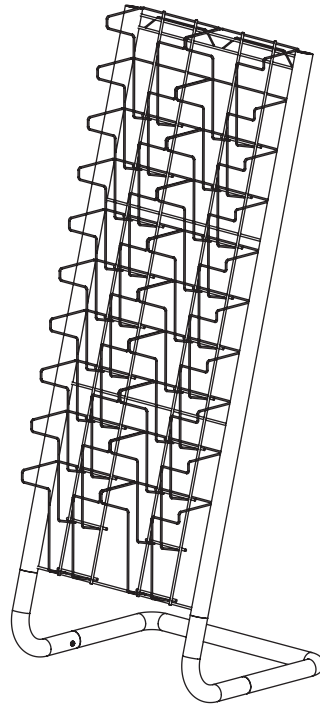

Parts

Description	QTY
A. Body	1
B. Base	1
C. Base Corner (left)	1
D. Base Corner (right)	1
E. M5x12 Self-Threading Screw	2

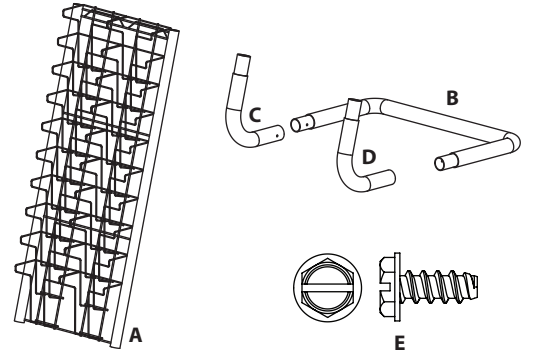

1:

1a: Slide both Base Corners (C/D) onto the Base (B), making sure that the hole on the Base Corner is aligned with the hole on the Base.

1b: With the holes aligned, secure the Base Corners to the Base using the (2) M5x12 Self-Threading Screws (E).

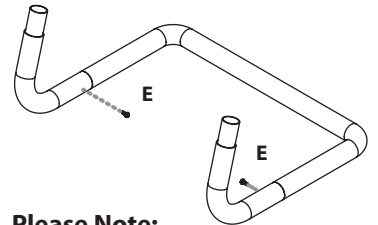
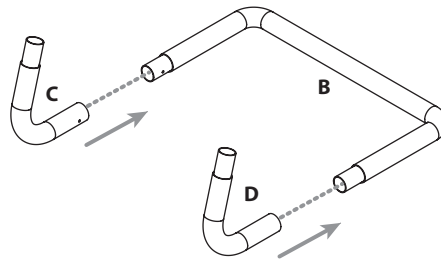

Please Note:

Do not fully tighten the screws until step 2 has been completed.

2: Line up the tubes on the Body (A) and simply slide the Body down onto the Base. After the Body is seated on Base fully tighten the screws.

