

Instructions:

* **If you are attaching this case to a stand/mount, attach the back plate (C) first to the stand/mount before proceeding to step one.**

1. Place iPad Air into the cut out of the center plate (B). If you wish to have the iPad plugged in to the charger you must attach the power cord now and make sure its through the channel at the bottom of the center plate (B).
2. Sandwich the center plate (B) with the iPad, in between the front (A) and back (C) plates. Rotate the front plate (A) if you want the home button exposed or covered just rotate the front plate accordingly.
3. Using the 1/2" screws, washers, and screw posts, fasten all three plates together, tightening it with the wrench.
4. Your iPad Air case is now complete, enjoy!

Hardware:

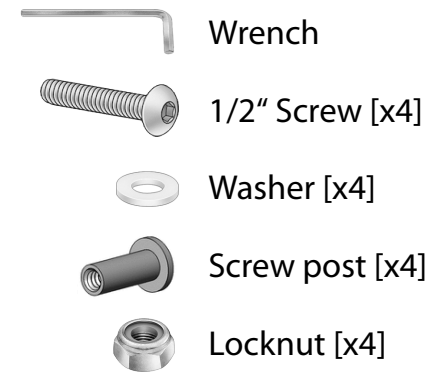

A - Front Plate

B - Center Plate

C - Back Plate

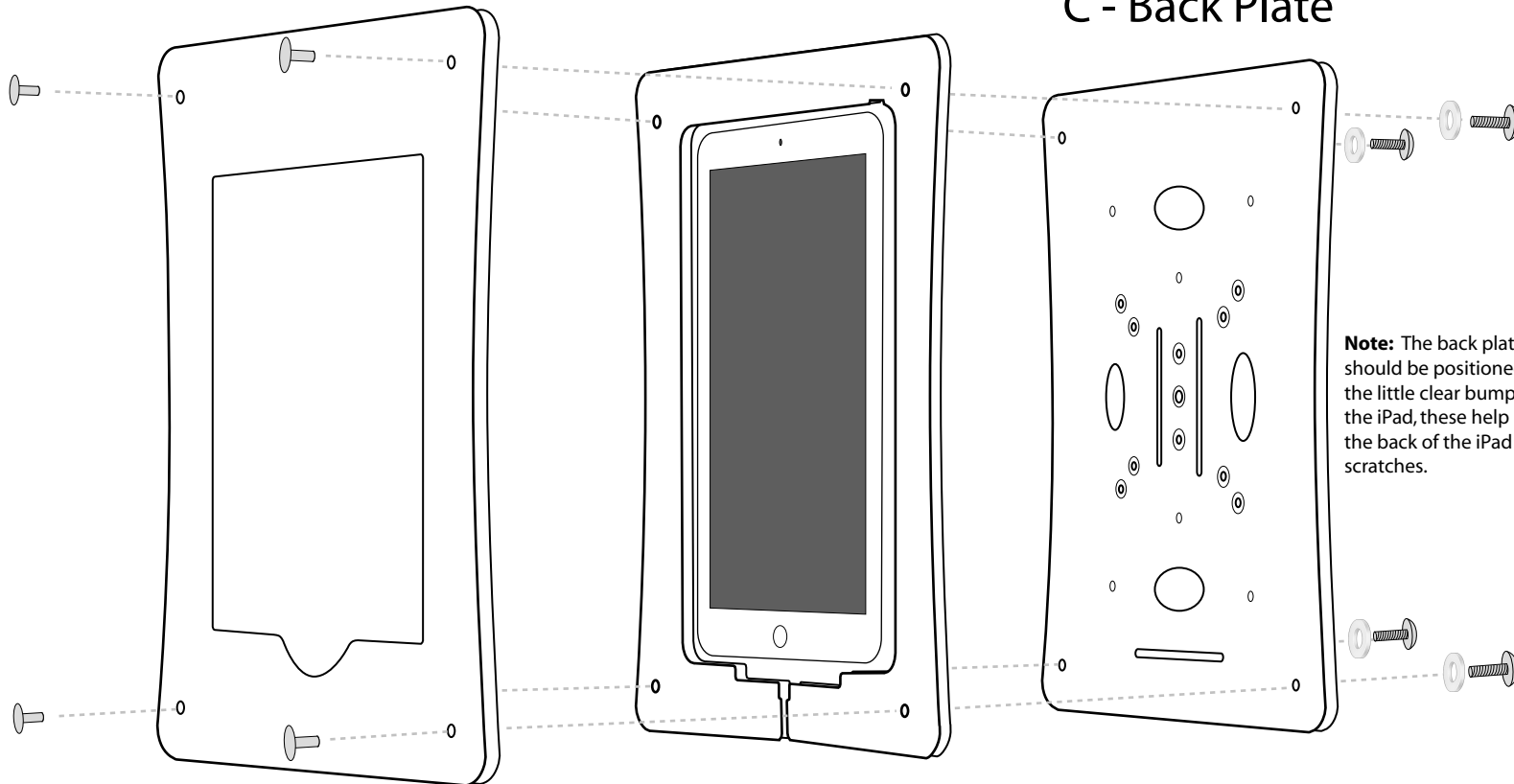

Note: The back plate (C) should be positioned with the little clear bumps facing the iPad, these help protect the back of the iPad from scratches.

Max Load: 8 Kgs

1.

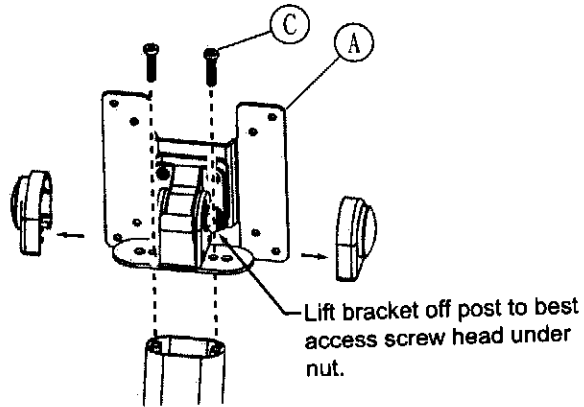

Part List:

B. M4x10 4 pcs

C. M5x16 2 pcs

D. 4 pcs

E. 4 pcs

F. 4 pcs

G. 1 pc

H. 1 pc

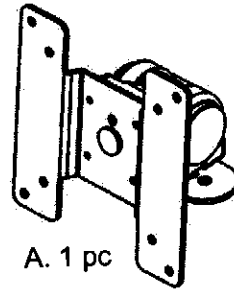

A. 1 pc

or 1. Screws supplied with stand.

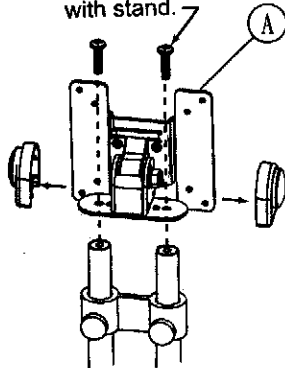

2.

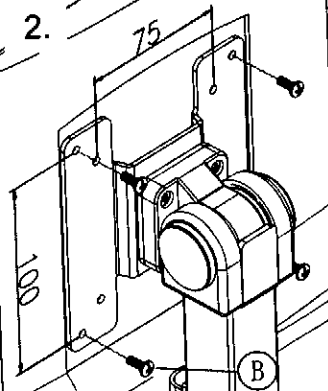

Spacers, parts D/E/F, are used to allow screw B to tighten screen to bracket

Adjust torque...if necessary

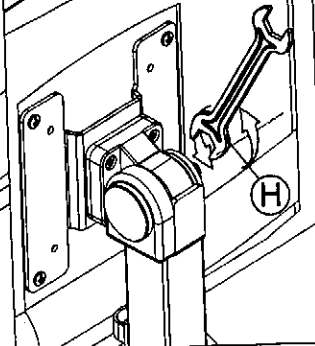

3.

